

# ARRISCRAFT • NOTE

## BUILDING MOVEMENT JOINTS



ARRISCRAFT™  
INTERNATIONAL  
BUILDING STONE • BRICK • LIMESTONE

### Introduction

This ARRISCRAFT•NOTE discusses the proper placement and construction of building movement joints in masonry veneer walls.

There are basically two distinct types of movement joints used in construction elastic and inelastic. Both of these joint types are designed to perform a specific function, and they should not be used interchangeably.

Inelastic movement joints would include construction joints and control joints.

- *Construction joints* are used wherever the construction work is to be interrupted. They are usually located where they will least impair the strength of the structure.
- *Control joints* in masonry construction are largely used in concrete unit masonry construction to create a plane of weakness. When used in conjunction with joint reinforcement, they control the location of cracks due to volume changes resulting from shrinkage and creep but are not generally sufficient to accommodate net material expansion.

Elastic movement joints include expansion joints and building joints.

- *Building expansion joints* are used to separate a building into discrete sections so that stresses developed in one section will not affect the integrity of the entire structure.
- *Expansion joints* for masonry construction are used mainly in clay brick, calcium-silicate unit masonry, or stone construction. They are used to segment the veneer to prevent cracking due to changes in temperature, moisture expansion, elastic deformation due to loads, and creep. They may be horizontal or vertical.

It is the elastic-type movement joint that is most appropriate for use in a masonry veneer application, and requirements for this type of joint will form the basis of the following discussion.

### Movement Joints in Masonry Veneer

Although primarily used to accommodate movement, building movement joints must also resist moisture penetration and air infiltration. They can be constructed in a variety of different ways to fulfill these requirements. They may include waterstops and pre-moulded foam or neoprene pads as barriers to keep

mortar or other debris from clogging the joint. These materials must be highly compressible and elastic in nature in order to accommodate the expansion and contraction of the veneer materials. As such, the use of fiberboard or other similar materials are not recommended for use in movement joints.

Materials such as mortar or joint reinforcement should not bridge the expansion joint as they would restrict movement and not allow the movement joint to perform its intended function.

A good quality backer rod and joint sealant should be used to seal the exterior of the movement joint against moisture and air penetration. The sealant material should be selected by the designer to be highly elastic, resistant to weathering and ultraviolet radiation, and compatible with the masonry materials, including any adjacent materials such as flashing membranes, metal components, etc.

Vertical movement joint frequency and size should be designed to accommodate the anticipated movement of the veneer materials. The joints must be of sufficient size to contend with the anticipated movements, without being so large as to be difficult to weather-proof. Typically, joints sized to resemble a mortar joint will be adequate to accommodate the anticipated movements and still be easily sealed against the elements.

The design of horizontal movement joints depends largely upon the anticipated loads and resulting deflections which are expected to occur at their particular locations.

To some degree the type of joint sealer being used must also be considered when determining the maximum and minimum allowable joint widths. The sealant must be able to span the joint and accommodate the anticipated movements. The sealant's recommended joint width-depth ratio should be considered during the design of the movement joint. As a rule of thumb, however, joint sealers used in expansion joints should have depth of not less than 6 mm (1/4") in order to ensure adequate protection against moisture and air penetration.

### Placement of Building Movement Joints

The actual location and frequency of movement joints is dependent upon the configuration of the structure as well as the expected amount of movement dictated by micro-environmental factors. They need to be designed as part of the building envelope by the designer and

must be clearly indicated on the building elevations as to their location and extent. As a general rule of thumb, movement joints should be located in the following locations:

- at changes in wall direction, such as at building corners;
- at wall openings, such as at windows and doors;
- at changes in building height, such as at building junctions;
- at major changes in thickness of wall, such as at pilasters;
- at periodic lengths of a continuous wall
- at changes of building materials; and
- below shelf angles.

*Corners:* Walls perpendicular to one another will expand towards their juncture, typically causing distress at the first head joint on either side of the corner. Movement joints should be placed near corners to alleviate this stress (Refer to Figure 1).

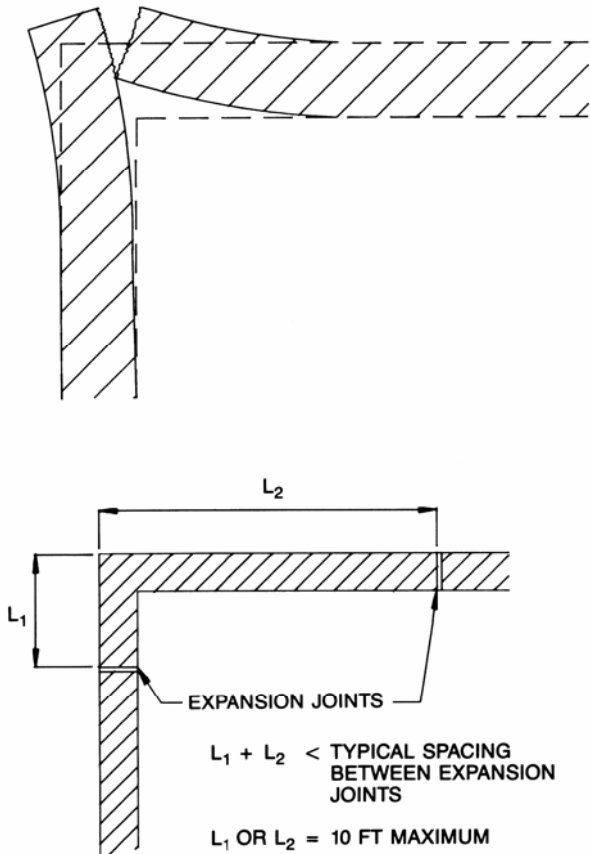

**Figure 1**

*Intersections, Offsets and Setbacks:* Parallel walls expand towards the offset rotating the short masonry leg or causing cracks within the offset. Building movement joints should be placed at the offset to allow the parallel walls to expand (Refer to Figure 2).

Intersecting walls not required to be bonded should also include a movement joint at the intersection.

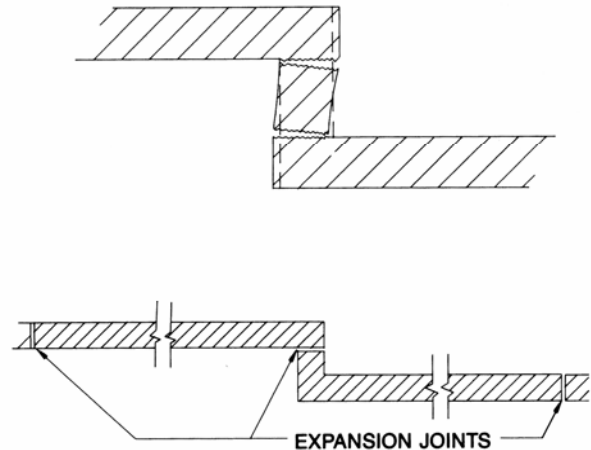

**Figure 2**

*Wall Openings:* More movement will tend to occur above and below window and door openings rather than between openings due to the change in the wall's mass. The differential movement between areas of different wall mass may cause cracks to emanate from the corners of the openings. As these openings also tend to "weaken" the wall, they act as naturally occurring movement joints.

It is often desirable to locate the veneer movement joint along the edge or jamb of the opening. In cases where the masonry above the opening is supported by steel shelf angles connected directly to the building structure, a vertical movement joint can be placed alongside the opening, continuing through the horizontal support. More commonly, however, masonry above the opening is supported by a loose steel lintel, thereby necessitating special detailing and construction of the movement joint at these locations. Consideration of the steel angle's need to expand and contract independent of the masonry necessitates incorporating a slip plane along the bed of the lintel (Refer to Figure 3). If this cannot be done, it may be better to locate the movement joint elsewhere, perhaps midway between openings.

*Junctions/Changes in Wall Height:* Just as with wall openings, large variations in wall height should include a movement joint at the juncture to accommodate the differential movement tendencies of the two different wall masses.

*Periodic Lengths of Continuous Wall:* Large expanses of masonry veneer will, by virtue of the aggregate sum of their individual dimensional changes, experience significant strain over the length of the wall. To alleviate this effect continuous vertical movement

joints should be incorporated along the length of the wall, generally at a spacing of between 7.5-9.0 metres (25-30 feet) maximum.

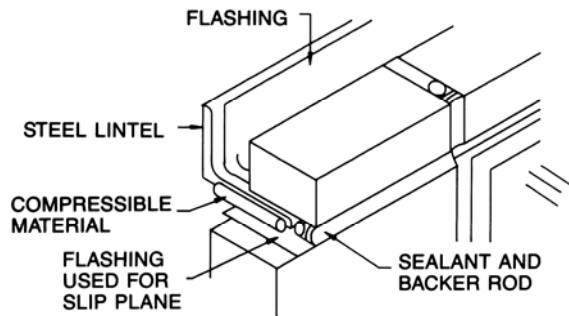

Figure 3

The designer's choice of mortar type will affect the flexibility of the hardened mortar and thus the flexibility of the veneer. The wall's ability to accommodate and distribute stresses will be reduced when stronger, less flexible mortar mixes are used. In such instances the designer should consider increasing the frequency of movement joints along periodic lengths of continuous wall.

*Changes in Building Materials:* Different materials will react differently to the effects of thermal and moisture change. For example, aluminum frames and masonry products will expand and contract at widely differing rates. The effects of such differential movement need to be accounted for and accommodated by the inclusion of a properly sized movement joint.

*Below Shelf Angles:* Horizontal movement joints are required wherever the masonry veneer has been supported on a shelf angle outside the frame. They are typically created by providing a space beneath the angle for movement to occur (Refer to Figure 4). Differential movements of the veneer materials and the structural frame should both be considered.

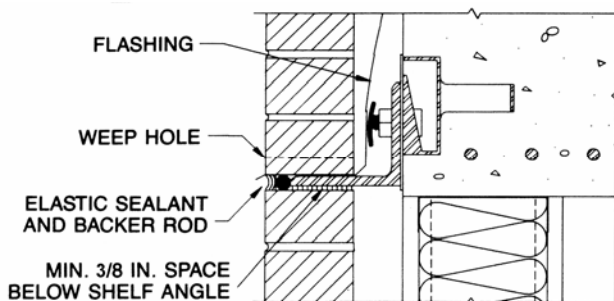

Figure 4

#### Other Considerations Affecting Placement

Placement of movement joints may also be influenced by additional factors. For instance, parapets are

exposed on three sides to extremes of moisture and temperature. This may cause substantially different movement from that of the wall below. Parapets also lack the dead load of masonry above to help resist movement. Therefore, all vertical movement joints should be carried through the parapets, and additional movement joints may be necessary halfway between those running full height unless the parapet is reinforced. Such additional joints would need to continue down to a horizontal movement joint or continue to the base of the wall.

Wherever spandrel sections of masonry are supported by a beam or floor slab through a shelf angle, the veneer may crack due to deflection of the support. By reducing the spacing between the vertical movement joints, deflection of the support element may occur without cracking the veneer.

Allowance for differential movement between the building veneer and the structure should also be provided. This can most easily be accommodated around wall openings and at the tops of walls.

#### Summary

This ARRISCRAFT•NOTE describes the different kinds of joints found in building construction and discusses the appropriate design and use of movement joints in masonry veneer construction.

Movement joints are used in masonry construction to allow for the differential movement generated by materials as they react to their own properties, environmental conditions and loads. In general, vertical movement joints should be used to break the masonry into rectangular elements that have the same support conditions, the same climatic exposure and the same through-wall construction. Horizontal movement joints should be placed below shelf angles supporting masonry.

The information and suggestions contained herein are based upon the available data and information published by the listed references and the experience of Arriscraft International architectural and engineering staff. More detailed information may be found by referring to any of the related references listed below.

The information contained herein must be used in conjunction with good technical judgement and a competent understanding of masonry construction. Final decisions on the use of the information contained in this ARRISCRAFT•NOTE are not within the purview of Arriscraft International and must rest with the project designer or owner, or both. It remains the sole responsibility of the designer to properly design the project, ensure all architectural and engineering

principles are properly applied throughout, and ensure that any suggestions made by Arriscraft International are appropriate in the instance and are properly incorporated through the project.

#### **Related References**

1. Brick Industry Association, Technical Notes on Brick Construction 18 (Revised), Volume Changes and Effect of Movement, Part I, January 1991.
2. Brick Industry Association, Technical Notes on Brick Construction 18A (Revised), Design and Detailing of Movement Joints, Part II, December 1991 (Reissued September 2001).
3. Canada Mortgage and Housing Corporation, Best Practice Guide, Brick Veneer Concrete Masonry Unit Backing, 1997.
4. Drysdale, Hamid, Baker; Masonry Structures - Behavior and Design - Second Edition, The Masonry Society, 1999.
5. Ontario Masonry Industry Promotion Fund, 4C 8202, Movement Control, February 1982.
6. Ontario Masonry Industry Promotion Fund, 4C 8504, Restraints and Movements in Masonry Walls, April 1985.

#### **Arriscraft International**

P.O. Box 3190

875 Speedsville Road

Cambridge, Ontario

Canada N3H 4S8

Toll Free: (800) 265-8123

Telephone: (519) 653-3275

Fax: (519) 653-1337

E-mail: [solutions@arriscraft.com](mailto:solutions@arriscraft.com)

Web: [www.arriscraft.com](http://www.arriscraft.com)